

Doc. Number :

- Tentative Specification
- Preliminary Specification
- Approval Specification

**MODEL NO.: G121AGE**  
**SUFFIX: L03**

<b>Customer:</b>	
<b>APPROVED BY</b>	<b>SIGNATURE</b>
Name / Title _____	_____
Note _____	
_____	
Please return 1 copy for your confirmation with your signature and comments.	

Approved By	Checked By	Prepared By

- CONTENTS -

REVISION HISTORY	-----	3
1. GENERAL DESCRIPTION	-----	4
1.1 OVERVIEW		
1.2 FEATURES		
1.3 APPLICATION		
1.4 GENERAL SPECIFICATIONS		
1.5 MECHANICAL SPECIFICATIONS		
2. ABSOLUTE MAXIMUM RATINGS	-----	6
2.1 ABSOLUTE RATINGS OF ENVIRONMENT		
2.2 ELECTRICAL ABSOLUTE RATINGS		
2.2.1 TFT LCD MODULE		
2.2.2 LED CONVERTER		
3. ELECTRICAL CHARACTERISTICS	-----	8
3.1 TFT LCD MODULE		
3.2 BACKLIGHT UNIT		
4. BLOCK DIAGRAM	-----	11
4.1 TFT LCD MODULE		
5. INPUT TERMINAL PIN ASSIGNMENT	-----	12
5.1 TFT LCD MODULE		
5.2 BACKLIGHT UNIT		
5.3 COLOR DATA INPUT ASSIGNMENT		
6. INTERFACE TIMING	-----	15
6.1 INPUT SIGNAL TIMING SPECIFICATIONS		
6.2 POWER ON/OFF SEQUENCE		
6.3 THE INPUT DATA FORMAT		
6.4 SCANNING DIRECTION		
7. OPTICAL CHARACTERISTICS	-----	19
7.1 TEST CONDITIONS		
7.2 OPTICAL SPECIFICATIONS		
8. RELIABILITY TEST CRITERIA	-----	23
9. PACKAGING	-----	24
9.1 PACKING SPECIFICATIONS		
9.2 PACKING METHOD		
10. DEFINITION OF LABELS	-----	26
11. PRECAUTIONS	-----	27
11.1 ASSEMBLY AND HANDLING PRECAUTIONS		
11.2 SAFETY PRECAUTIONS		
12. MECHANICAL CHARACTERISTICS	-----	28

REVISION HISTORY

Version	Date	Section	Description
0.0	Nov.06. 2012	All	G121AGE-L03 Tentative Spec. was first issued.

## 1. GENERAL DESCRIPTION

### 1.1 OVERVIEW

The G121AGE-L03 model is a 12.1" TFT-LCD module with a white LED Backlight Unit and a 20-pin 1ch-LVDS interface. This module supports 800 x 600 SVGA MVA mode and displays 262K/ 16.2M colors. The converter for the LED Backlight Unit is built in.

### 1.2 FEATURES

- Wide viewing angle
- High contrast ratio
- SVGA (800 x 600 pixels) resolution
- Wide operating temperature
- DE (Data Enable) mode
- LVDS (Low Voltage Differential Signaling) interface
- Reversible-scan direction
- RoHS Compliance
- LED Light Bar Replaceable

### 1.3 APPLICATION

- TFT LCD Monitor
- Industrial Application
- Amusement

### 1.4 GENERAL SPECIFICATIONS

Item	Specification	Unit	Note
Diagonal Size	12.1	inch	(1)
Active Area	246.00(H) x 184.50(V)	mm	
Bezel Opening Area	249.00(H) x 187.50(V)	mm	
Driver Element	a-si TFT active matrix	-	-
Pixel Number	800 x R.G.B. x 600	pixel	-
Pixel Pitch	0.3075(H) x 0.3075(V)	mm	-
Pixel Arrangement	RGB vertical stripe	-	-
Display Colors	262K/ 16.2M	color	-
Transmissive Mode	Normally black	-	-
Surface Treatment	Hard coating (3H), Anti-glare (Haze 25%)	-	-
Module Power Consumption	( 9 )	W	(3), Typ

1.5 MECHANICAL SPECIFICATIONS

Item		Min.	Typ.	Max.	Unit	Note
Module Size	Horizontal (H)	260.0	260.5	261.0	mm	(1)
	Vertical (V)	203.5	204.0	204.5	mm	
	Depth (D)	7.9	8.4	8.9	mm	
Weight		---	(506)	(530)	g	-
I/F connector mounting position		The mounting inclination of the connector makes the screen center within $\pm 0.5\text{mm}$ as the horizontal.			-	(2)

Note (1) Please refer to the attached drawings for more information of front and back outline dimensions.

(2) Connector mounting position

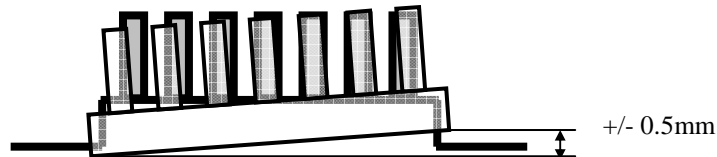

(3) The Module Power Consumption is specified at 3.3V, white pattern and 100% duty for LED backlight.

2. ABSOLUTE MAXIMUM RATINGS

2.1 ABSOLUTE RATINGS OF ENVIRONMENT

Item	Symbol	Value		Unit	Note
		Min.	Max.		
Operating Ambient Temperature	T <sub>OP</sub>	-30	+80	°C	
Storage Temperature	T <sub>ST</sub>	-30	+85	°C	

Note (1) Temperature and relative humidity range is shown in the figure below.

- (2) 90 %RH Max. (Ta ≤ 40 °C).
- (3) Wet-bulb temperature should be 39 °C Max. (Ta > 40 °C).
- (4) No condensation.

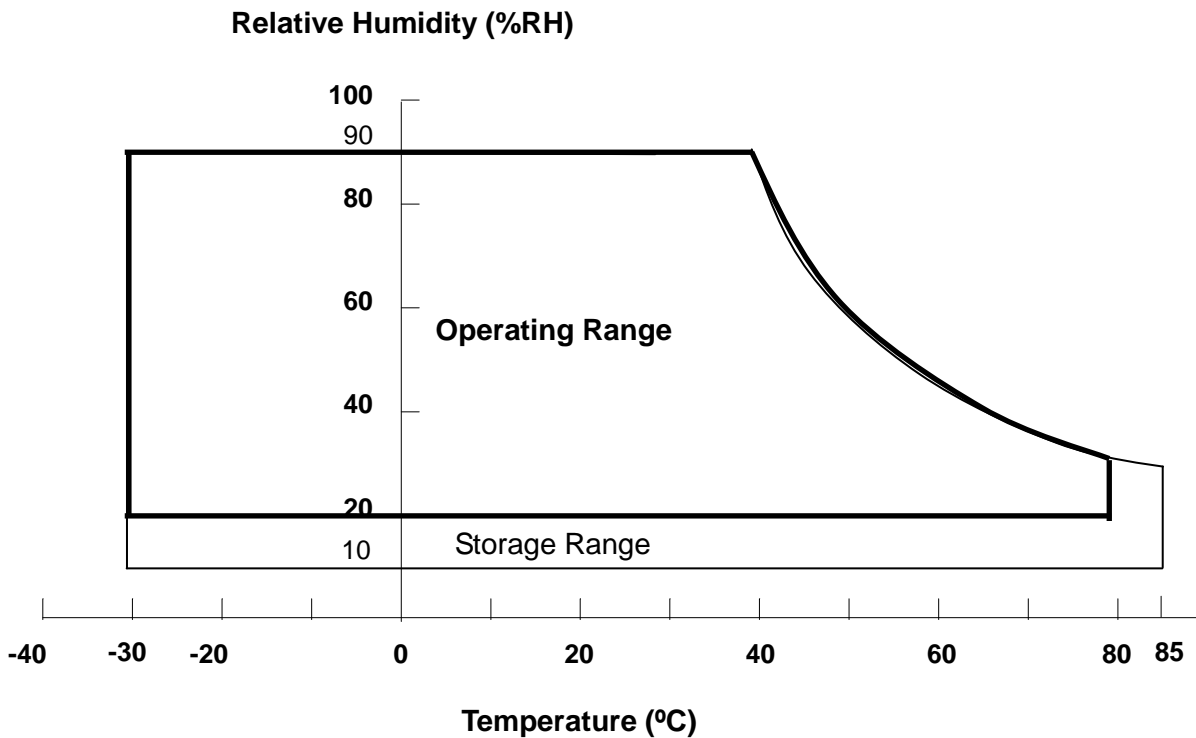

2.2 ELECTRICAL ABSOLUTE RATINGS

2.2.1 TFT LCD MODULE

Item	Symbol	Value		Unit	Note
		Min.	Max.		
Power Supply Voltage	VCC	-0.3	7	V	(1)

2.2.2 LED CONVERTER

Item	Symbol	Value		Unit	Note
		Min.	Max.		
Converter Voltage	$V_i$	-0.3	18	V	(1), (2)
Enable Voltage	EN	---	5.5	V	
Backlight Adjust	ADJ	---	5.5	V	

Note (1) Permanent damage to the device may occur if maximum values are exceeded. Function operation should be restricted to the conditions described under Normal Operating Conditions.

Note (2) Specified values are for lamp (Refer to 3.2 for further information).

3. ELECTRICAL CHARACTERISTICS

3.1 TFT LCD MODULE

Ta = 25 ± 2 °C

Parameter	Symbol	Value			Unit	Note	
		Min.	Typ.	Max.			
Power Supply Voltage	VCC	(3.0)	3.3	(3.6)	V	at VCC=3.3V	
		(4.75)	(5.0)	(5.25)	V	at VCC=5.0V	
Rush Current	I <sub>RUSH</sub>	-	-	(1.5)	A	(2), at VCC=5.0V	
Power Supply Current	White	---	---	(460)	---	mA	(3)a, at VCC=3.3V, 60Hz
			---	(310)	---	mA	(3)a, at VCC=5.0V, 60Hz
	Black	---	---	(420)	---	mA	(3)b, at VCC=3.3V, 60Hz
			---	(280)	---	mA	(3)b, at VCC=5.0V, 60Hz
Power Consumption	P <sub>L</sub>	---	(1.52)		W	VCC=3.3V, 60Hz, White Pattern	
LVDS differential input voltage	VID	(100)	---	(600)	mV	-	
LVDS common input voltage	VICM	(0.7)	---	(1.6)	V	-	

Note (1) The module is recommended to operate within specification ranges listed above for normal function.

Note (2) Measurement Conditions:

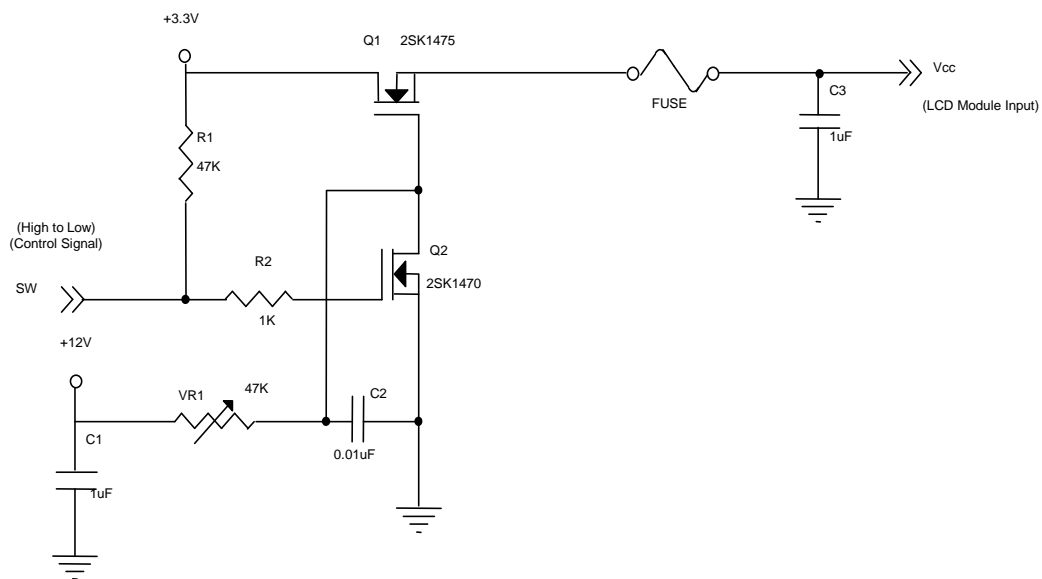

**Vcc rising time is 470μs**

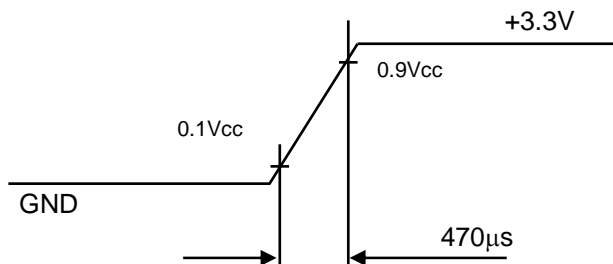



Note (3) The specified power supply current is under the conditions at  $T_a = 25 \pm 2 \text{ }^\circ\text{C}$ ,  $f_v = 60 \text{ Hz}$ , whereas a power dissipation check pattern below is displayed.

a. White Pattern



Active Area

b. Black Pattern



Active Area

3.2 LED CONVERTER

Ta = 25 ± 2 °C

Parameter	Symbol	Value			Unit	Note
		Min.	Typ.	Max.		
Converter Power Supply Voltage	V <sub>i</sub>	(10.8)	12.0	(13.2)	V	(Duty 100%)
Converter Power Supply Current	I <sub>i</sub>	---	(0.53)	---	A	@ Vi = 12V (Duty 100%)
Converter Power Consumption	P <sub>i</sub>	---	(6.4)	---	W	@ Vi = 12V (Duty 100%)
EN Control Level	Backlight on	(2.0)	3.3	(5.0)	V	
	Backlight off	(0)	---	(0.8)	V	
PWM Control Level	PWM High Level	(2.0)	3.3	(5.0)	V	
	PWM Low Level	(0)	---	(0.15)	V	
PWM Control Duty Ratio		(20)		(100)	%	
PWM Control Frequency	f <sub>PWM</sub>	(190)	(200)	(20K)	Hz	
LED Life Time	L <sub>L</sub>	(50,000)			Hrs	(2)

Note (1) LED current is measured by utilizing a high frequency current meter as shown below:

Note (2) The lifetime of LED is defined as the time when it continues to operate under the conditions at Ta = 25 ± 2 °C and I<sub>LED</sub> = 55mA<sub>DC</sub> (LED forward current) until the brightness becomes ≤ 50% of its original value. Operating LED under high temperature environment will reduce life time and lead to color shift.

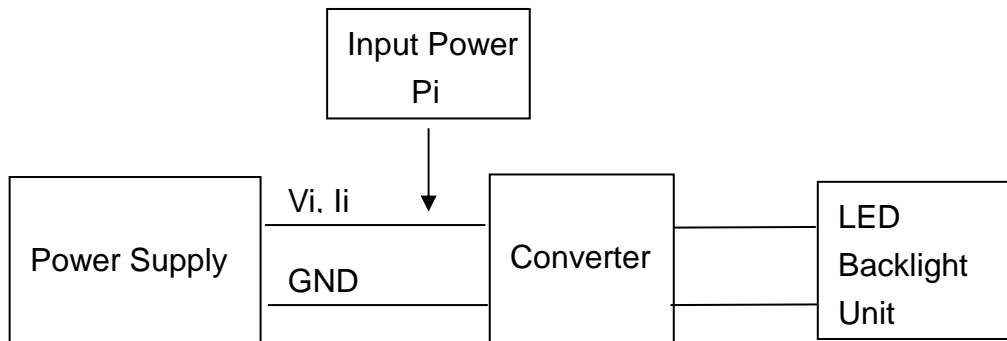

4. BLOCK DIAGRAM

4.1 TFT LCD MODULE

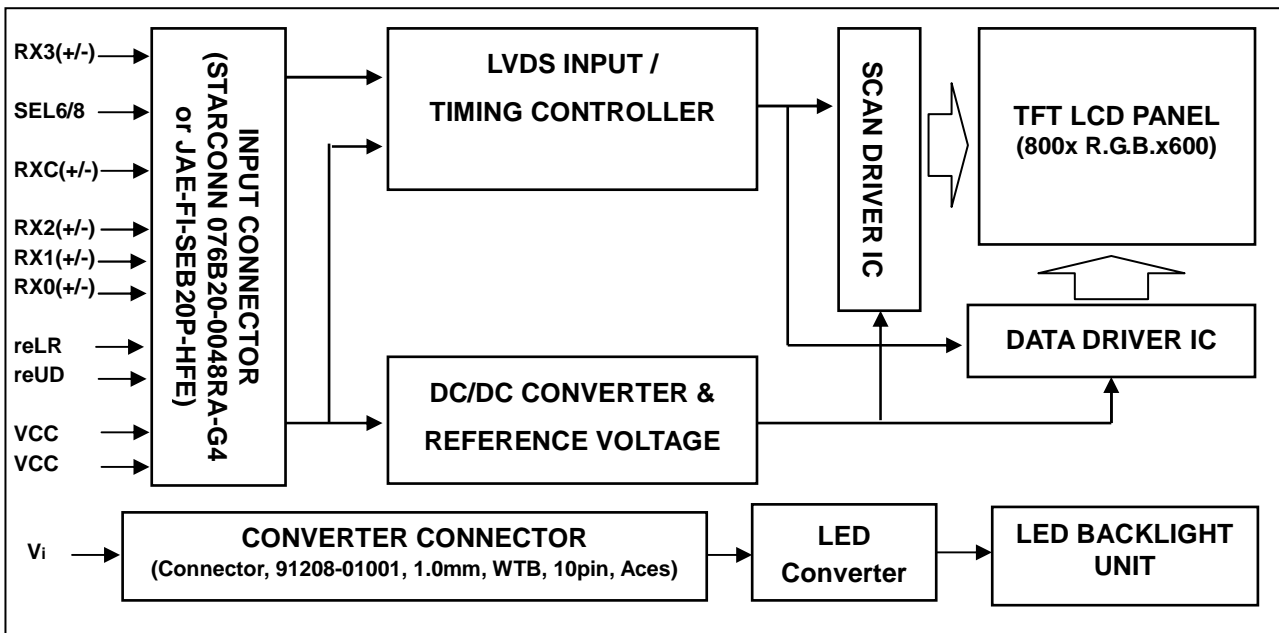

## 5. INPUT TERMINAL PIN ASSIGNMENT

### 5.1 TFT LCD MODULE

Pin	Name	Description	Remark
1	RX3+	Differential Data Input, CH3 ( Positive )	
2	RX3-	Differential Data Input, CH3 (Negative )	
3	GND	GND	
4	SEL68	LVDS 6/8 bit select function control, Low or NC → 6 bit Input Mode High → 8bit Input Mode	Note ( 3 )
5	GND	Ground	
6	RXC+	Differential Clock Input ( Positive )	LVDS Level Clock
7	RXC-	Differential Clock Input ( Negative )	
8	GND	Ground	
9	RX2+	Differential Data Input , CH2 ( Positive )	
10	RX2-	Differential Data Input , CH2 ( Negative )	
11	GND	Ground	
12	RX1+	Differential Data Input , CH1 ( Positive )	
13	RX1-	Differential Data Input, CH1 ( Negative )	
14	GND	Ground	
15	RX0+	Differential Data Input, CH0 ( Positive )	
16	RX0-	Differential Data Input, CH0 (Negative )	
17	reLR	Horizontal Reverse Scan Control, Low or NC → Normal Mode. High → Horizontal Reverse Scan	Note ( 3 )
18	reUD	Vertical Reverse Scan Control, Low or NC → Normal Mode, High → Vertical Reverse Scan	Note ( 3 )
19	VCC	Power supply	
20	VCC	Power supply	

Note (1) Connector Part No.: FI-SEB20P-HFE(JAE) or 076B20-0048RA-G4(STARCONN) or equivalent.

Note (2) User's connector Part No.: FI-SE20ME(JAE) or equivalent

Note (3) "Low" stands for 0V. "High" stands for 3.3V. "NC" stands for "No Connected".

### 5.2 LED CONVERTER

Pin	Symbol	Description	Remark
1	$V_i$	Converter input voltage	12V
2	$V_i$	Converter input voltage	12V
3	$V_i$	Converter input voltage	12V
4	$V_i$	Converter input voltage	12V
5	$V_{GND}$	Converter ground	Ground
6	$V_{GND}$	Converter ground	Ground
7	$V_{GND}$	Converter ground	Ground
8	$V_{GND}$	Converter ground	Ground
9	EN	Enable pin	3.3V
10	ADJ	Backlight Adjust	PWM Dimming (190-20KHz, Hi: 3.3V <sub>DC</sub> , Lo: 0V <sub>DC</sub> )

Note (1) Connector Part No.: 91208-01001-H01(ACES) or equivalent

Note (2) User's connector Part No.: 91209-01011(ACES) or equivalent

5.3 COLOR DATA INPUT ASSIGNMENT

The brightness of each primary color (red, green and blue) is based on the 6-bit gray scale data input for the color. The higher the binary input, the brighter the color. The table below provides the assignment of color versus data input.

Color		Data Signal																	
		Red						Green						Blue					
		R5	R4	R3	R2	R1	R0	G5	G4	G3	G2	G1	G0	B5	B4	B3	B2	B1	B0
Basic Colors	Black	0	0	0	0	0	0	0	0	0	0	0	0	0	0	0	0	0	0
	Red	1	1	1	1	1	1	0	0	0	0	0	0	0	0	0	0	0	0
	Green	0	0	0	0	0	0	1	1	1	1	1	1	0	0	0	0	0	0
	Blue	0	0	0	0	0	0	0	0	0	0	0	0	1	1	1	1	1	1
	Cyan	0	0	0	0	0	0	1	1	1	1	1	1	1	1	1	1	1	1
	Magenta	1	1	1	1	1	1	0	0	0	0	0	0	0	1	1	1	1	1
	Yellow	1	1	1	1	1	1	1	1	1	1	1	1	0	0	0	0	0	0
	White	1	1	1	1	1	1	1	1	1	1	1	1	1	1	1	1	1	1
Gray Scale Of Red	Red(0)/Dark	0	0	0	0	0	0	0	0	0	0	0	0	0	0	0	0	0	0
	Red(1)	0	0	0	0	0	1	0	0	0	0	0	0	0	0	0	0	0	0
	Red(2)	0	0	0	0	1	0	0	0	0	0	0	0	0	0	0	0	0	0
	:	:	:	:	:	:	:	:	:	:	:	:	:	:	:	:	:	:	:
	:	:	:	:	:	:	:	:	:	:	:	:	:	:	:	:	:	:	:
	:	:	:	:	:	:	:	:	:	:	:	:	:	:	:	:	:	:	:
	Red(61)	1	1	1	1	0	1	0	0	0	0	0	0	0	0	0	0	0	0
	Red(62)	1	1	1	1	1	0	0	0	0	0	0	0	0	0	0	0	0	0
Red(63)	1	1	1	1	1	1	0	0	0	0	0	0	0	0	0	0	0	0	
Gray Scale Of Green	Green(0)/Dark	0	0	0	0	0	0	0	0	0	0	0	0	0	0	0	0	0	0
	Green(1)	0	0	0	0	0	0	0	0	0	0	0	1	0	0	0	0	0	0
	Green(2)	0	0	0	0	0	0	0	0	0	0	1	0	0	0	0	0	0	0
	:	:	:	:	:	:	:	:	:	:	:	:	:	:	:	:	:	:	:
	:	:	:	:	:	:	:	:	:	:	:	:	:	:	:	:	:	:	:
	:	:	:	:	:	:	:	:	:	:	:	:	:	:	:	:	:	:	:
	Green(61)	0	0	0	0	0	0	1	1	1	1	0	1	0	0	0	0	0	0
	Green(62)	0	0	0	0	0	0	1	1	1	1	1	0	0	0	0	0	0	0
Green(63)	0	0	0	0	0	0	1	1	1	1	1	1	0	0	0	0	0	0	
Gray Scale Of Blue	Blue(0)/Dark	0	0	0	0	0	0	0	0	0	0	0	0	0	0	0	0	0	0
	Blue(1)	0	0	0	0	0	0	0	0	0	0	0	0	0	0	0	0	0	1
	Blue(2)	0	0	0	0	0	0	0	0	0	0	0	0	0	0	0	0	1	0
	:	:	:	:	:	:	:	:	:	:	:	:	:	:	:	:	:	:	:
	:	:	:	:	:	:	:	:	:	:	:	:	:	:	:	:	:	:	:
	:	:	:	:	:	:	:	:	:	:	:	:	:	:	:	:	:	:	:
	Blue(61)	0	0	0	0	0	0	0	0	0	0	0	0	1	1	1	1	0	1
	Blue(62)	0	0	0	0	0	0	0	0	0	0	0	0	1	1	1	1	1	0
Blue(63)	0	0	0	0	0	0	0	0	0	0	0	0	1	1	1	1	1	1	

Note (1) 0: Low Level Voltage, 1: High Level Voltage

The brightness of each primary color (red, green and blue) is based on the 8-bit gray scale data input for the color. The higher the binary input, the brighter the color. The table below provides the assignment of color versus data input.

Color		Data Signal																						
		Red								Green								Blue						
		R7	R6	R5	R4	R3	R2	R1	R0	G7	G6	G5	G4	G3	G2	G1	G0	B7	B6	B5	B4	B3	B2	B1
Basic Colors	Black	0	0	0	0	0	0	0	0	0	0	0	0	0	0	0	0	0	0	0	0	0	0	0
	Red	1	1	1	1	1	1	1	1	0	0	0	0	0	0	0	0	0	0	0	0	0	0	0
	Green	0	0	0	0	0	0	0	0	1	1	1	1	1	1	1	1	0	0	0	0	0	0	0
	Blue	0	0	0	0	0	0	0	0	0	0	0	0	0	0	0	0	1	1	1	1	1	1	1
	Cyan	0	0	0	0	0	0	0	0	1	1	1	1	1	1	1	1	1	1	1	1	1	1	1
	Magenta	1	1	1	1	1	1	1	1	0	0	0	0	0	0	0	0	1	1	1	1	1	1	1
	Yellow	1	1	1	1	1	1	1	1	1	1	1	1	1	1	1	1	0	0	0	0	0	0	0
	White	1	1	1	1	1	1	1	1	1	1	1	1	1	1	1	1	1	1	1	1	1	1	1
Gray Scale Of Red	Red(0) / Dark	0	0	0	0	0	0	0	0	0	0	0	0	0	0	0	0	0	0	0	0	0	0	
	Red(1)	0	0	0	0	0	0	0	1	0	0	0	0	0	0	0	0	0	0	0	0	0	0	
	Red(2)	0	0	0	0	0	0	1	0	0	0	0	0	0	0	0	0	0	0	0	0	0	0	
	:	:	:	:	:	:	:	:	:	:	:	:	:	:	:	:	:	:	:	:	:	:	:	
	:	:	:	:	:	:	:	:	:	:	:	:	:	:	:	:	:	:	:	:	:	:	:	
	Red(253)	1	1	1	1	1	1	0	1	0	0	0	0	0	0	0	0	0	0	0	0	0	0	
	Red(254)	1	1	1	1	1	1	1	0	0	0	0	0	0	0	0	0	0	0	0	0	0	0	
	Red(255)	1	1	1	1	1	1	1	1	0	0	0	0	0	0	0	0	0	0	0	0	0	0	
Gray Scale Of Green	Green(0)/ Dark	0	0	0	0	0	0	0	0	0	0	0	0	0	0	0	0	0	0	0	0	0	0	
	Green(1)	0	0	0	0	0	0	0	0	0	0	0	0	0	0	1	0	0	0	0	0	0	0	
	Green(2)	0	0	0	0	0	0	0	0	0	0	0	0	0	1	0	0	0	0	0	0	0	0	
	:	:	:	:	:	:	:	:	:	:	:	:	:	:	:	:	:	:	:	:	:	:	:	
	:	:	:	:	:	:	:	:	:	:	:	:	:	:	:	:	:	:	:	:	:	:	:	
	Green(253)	0	0	0	0	0	0	0	0	1	1	1	1	1	1	0	1	0	0	0	0	0	0	
	Green(254)	0	0	0	0	0	0	0	0	1	1	1	1	1	1	1	0	0	0	0	0	0	0	
	Green(255)	0	0	0	0	0	0	0	0	1	1	1	1	1	1	1	1	0	0	0	0	0	0	
Gray Scale Of Blue	Blue(0) / Dark	0	0	0	0	0	0	0	0	0	0	0	0	0	0	0	0	0	0	0	0	0	0	
	Blue(1)	0	0	0	0	0	0	0	0	0	0	0	0	0	0	0	0	0	0	0	0	0	1	
	Blue(2)	0	0	0	0	0	0	0	0	0	0	0	0	0	0	0	0	0	0	0	0	0	1	
	:	:	:	:	:	:	:	:	:	:	:	:	:	:	:	:	:	:	:	:	:	:	:	
	:	:	:	:	:	:	:	:	:	:	:	:	:	:	:	:	:	:	:	:	:	:	:	
	Blue(253)	0	0	0	0	0	0	0	0	0	0	0	0	0	0	0	1	1	1	1	1	1	0	
	Blue(254)	0	0	0	0	0	0	0	0	0	0	0	0	0	0	0	1	1	1	1	1	1	1	
	Blue(255)	0	0	0	0	0	0	0	0	0	0	0	0	0	0	0	1	1	1	1	1	1	1	

Note: 0: Low Level Voltage, 1: High Level Voltage

6. INTERFACE TIMING

6.1 INPUT SIGNAL TIMING SPECIFICATIONS

The input signal timing specifications are shown as the following table and timing diagram.

Signal	Item	Symbol	Min.	Typ.	Max.	Unit	Note
DCLK	Frequency	Fc	(34)	(40)	(48.3)	MHz	
Vertical Active Display Term	Total	Tv	(610)	(628)	(800)	Th	Tv=Tvd+Tvb
	Display	Tvd	--	(600)	--	Th	
	Blank	Tvb	Tv-Tvd	(28)	Tv-Tvd	Th	
Horizontal Active Display Term	Total	Th	(960)	(1056)	(1150)	Tc	Th=Thd+Thb
	Display	Thd	--	(800)	--	Tc	
	Blank	Thb	Th-Thd	(256)	Th-Thd	Tc	

Note : (1) Because this module is operated by DE only mode, Hsync and Vsync input signals should be set to low logic level or ground. Otherwise, this module would operate abnormally.

(2) Frame rate is 60Hz

**INPUT SIGNAL TIMING DIAGRAM**

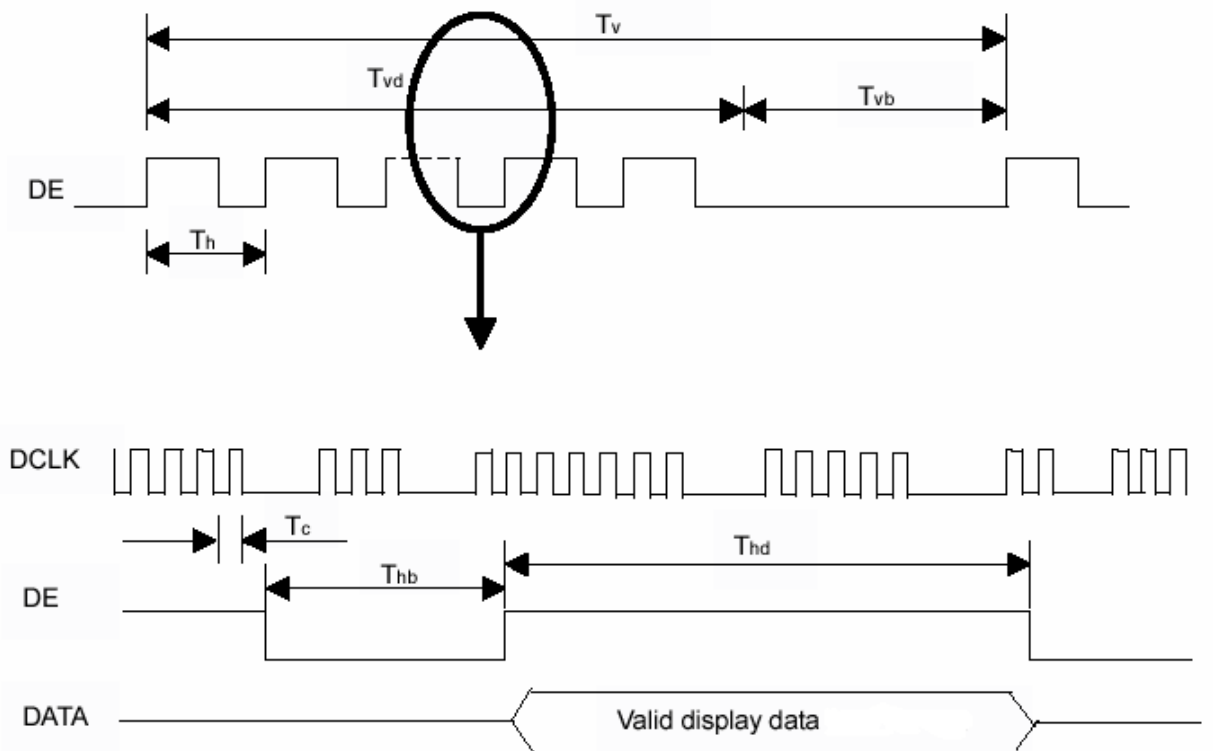

6.2 POWER ON/OFF SEQUENCE

To prevent a latch-up or DC operation of LCD module, the power on/off sequence should follow the conditions shown in the following diagram.

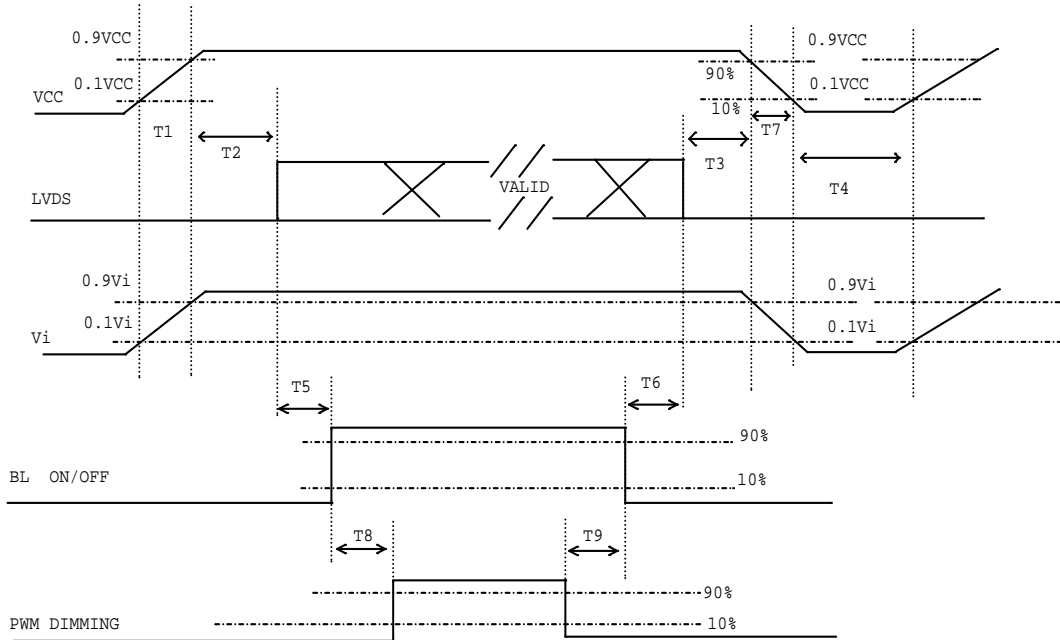

**Power ON/OFF sequence**

Note (1) Please avoid floating state of interface signal at invalid period.

Note (2) When the interface signal is invalid, be sure to pull down the power supply of LCD VCC to 0 V.

Note (3) The Backlight converter power must be turned on after the power supply for the logic and the interface signal is valid. The Backlight converter power must be turned off before the power supply for the logic and the interface signal is invalid.

Parameter	Value			Units
	Min	Typ	Max	
<b>T1</b>	<b>(0.5)</b>	---	<b>(10)</b>	<b>ms</b>
<b>T2</b>	<b>(0)</b>	---	<b>(50)</b>	<b>ms</b>
<b>T3</b>	<b>(0)</b>	---	<b>(50)</b>	<b>ms</b>
<b>T4</b>	<b>(500)</b>	---	---	<b>ms</b>
<b>T5</b>	<b>(200)</b>	---	---	<b>ms</b>
<b>T6</b>	<b>(200)</b>	---	---	<b>ms</b>
<b>T7</b>	<b>(5)</b>	---	<b>(300)</b>	<b>ms</b>
<b>T8</b>	<b>(10)</b>	---	---	<b>ms</b>
<b>T9</b>	<b>(10)</b>	---	---	<b>ms</b>



6.3 The INPUT DATA FORMAT

SEL68 = "Low" or "NC" for 6 bits LVDS Input

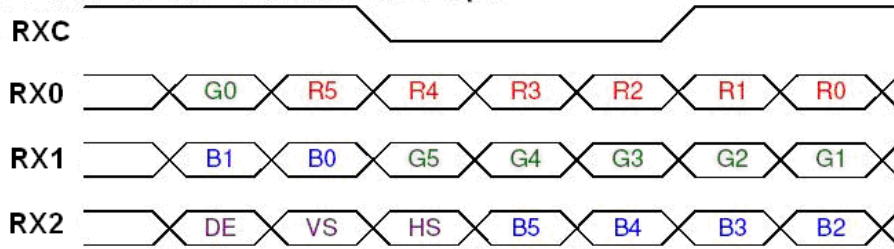

SEL68 = "High" for 8 bits LVDS Input

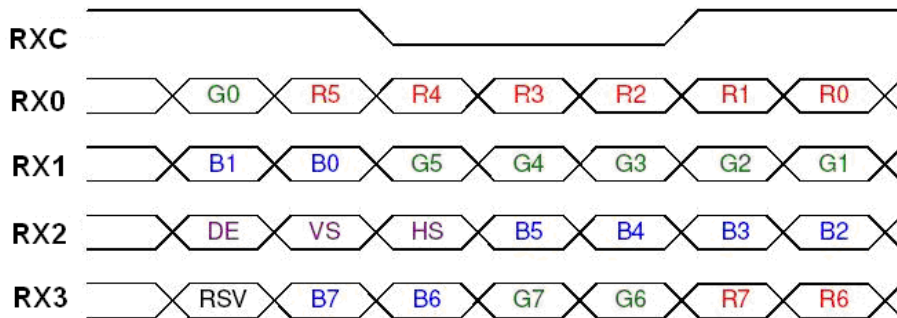

Note (1) R/G/B data 7: MSB, R/G/B data 0: LSB

Note (2) Please follow PSWG

Signal Name	Description	Remark
R7	Red Data 7 (MSB)	Red-pixel Data Each red pixel's brightness data consists of these 8 bits pixel data.
R6	Red Data 6	
R5	Red Data 5	
R4	Red Data 4	
R3	Red Data 3	
R2	Red Data 2	
R1	Red Data 1	
R0	Red Data 0 (LSB)	
G7	Green Data 7 (MSB)	Green-pixel Data Each green pixel's brightness data consists of these 8 bits pixel data.
G6	GreenData 6	
G5	GreenData 5	
G4	GreenData 4	
G3	GreenData 3	
G2	GreenData 2	
G1	GreenData 1	
G0	GreenData 0 (LSB)	
B7	Blue Data 7 (MSB)	Blue-pixel Data Each blue pixel's brightness data consists of these 8 bits pixel data.
B6	Blue Data 6	
B5	Blue Data 5	
B4	Blue Data 4	
B3	Blue Data 3	
B2	Blue Data 2	
B1	Blue Data 1	
B0	Blue Data 0 (LSB)	
RXCLKIN+ RXCLKIN-	LVDS Clock Input	
DE	Display Enable	
VS	Vertical Sync	
HS	Horizontal Sync	

Note (3) Output signals from any system shall be low or Hi-Z state when VCC is off

6.4 SCANNING DIRECTION

The following figures show the image see from the front view. The arrow indicates the direction of scan.

Fig.1 Normal Scan



Fig.2 Reverse Scan



Fig.3 Reverse Scan



Fig.4 Reverse Scan



Fig. 1 Normal scan ( pin 17, reLR = Low or NC, pin 18, reUD = Low or NC )

Fig. 2 Reverse scan ( pin 17, reLR = High, pin 18, reUD = Low or NC )

Fig. 3 Reverse scan ( pin 17, reLR = Low or NC, pin 18, reUD = High )

Fig. 4 Reverse scan ( pin 17, reLR = High, pin 18, reUD = High )

## 7. OPTICAL CHARACTERISTICS

### 7.1 TEST CONDITIONS

Item	Symbol	Value	Unit
Ambient Temperature	Ta	(25±2)	°C
Ambient Humidity	Ha	(50±10)	%RH
Supply Voltage	V <sub>CC</sub>	(3.3)	V
Input Signal	According to typical value in "3. ELECTRICAL CHARACTERISTICS"		
Converter Voltage	V <sub>in</sub>	(12)	V
Converter Duty		(100)	%

### 7.2 OPTICAL SPECIFICATIONS

The relative measurement methods of optical characteristics are shown in 7.2. The following items should be measured under the test conditions described in 7.1 and stable environment shown in Note (5).

Item		Symbol	Condition	Min.	Typ.	Max.	Unit	Note					
Color Chromaticity	Red	R <sub>x</sub>	$\theta_x=0^\circ, \theta_y=0^\circ$ CS-2000	Typ - 0.05	(0.600)	Typ + 0.05	-	(1), (5)					
		R <sub>y</sub>			(0.353)		-						
	Green	G <sub>x</sub>			(0.348)		-						
		G <sub>y</sub>			(0.568)		-						
	Blue	B <sub>x</sub>			(0.150)		-						
		B <sub>y</sub>			(0.097)		-						
	White	W <sub>x</sub>			(0.333)		-						
		W <sub>y</sub>			(0.359)		-						
	Center Luminance of White				L <sub>C</sub>				(400)	(450)		-	(4), (5)
	Contrast Ratio				CR				(1200)	(1500)		-	(2), (5)
Response Time		T <sub>R</sub>	$\theta_x=0^\circ, \theta_y=0^\circ$	-	(13)	(18)	ms	(3)					
		T <sub>F</sub>		-	(12)	(17)	ms						
White Variation		$\delta W$	$\theta_x=0^\circ, \theta_y=0^\circ$	-	(1.25)	(1.33)	-	(5), (6)					
Viewing Angle	Horizontal	$\theta_{x+}$	CR≥10	(80)	(89)	-	Deg.	(1), (5)					
		$\theta_{x-}$		(80)	(89)	-							
	Vertical	$\theta_{y+}$		(80)	(89)	-							
		$\theta_{y-}$		(80)	(89)	-							

Note (1) Definition of Viewing Angle ( $\theta_x, \theta_y$ ):

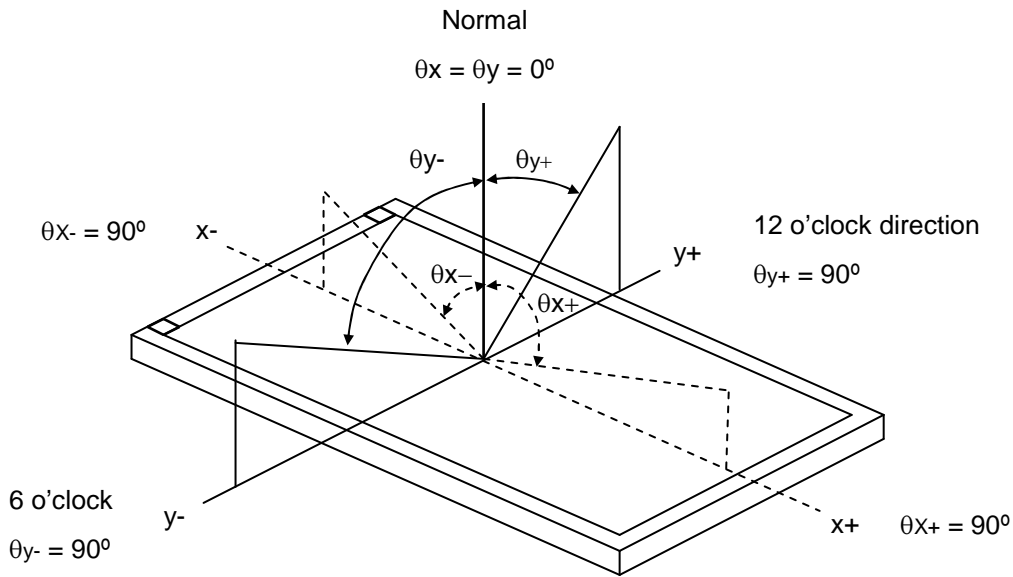

Note (2) Definition of Contrast Ratio, CR:

The contrast ratio can be calculated by the following expression.

$$\text{Contrast Ratio, CR} = L_{63} (255) / L_0$$

L63: Luminance of gray level 63 (255)

L 0: Luminance of gray level 0

$$\text{CR} = \text{CR} (5)$$

CR (X) is corresponding to the Contrast Ratio of the point X at Figure in Note (6).

Note (3) Definition of Response Time ( $T_R, T_F$ ) and measurement method:

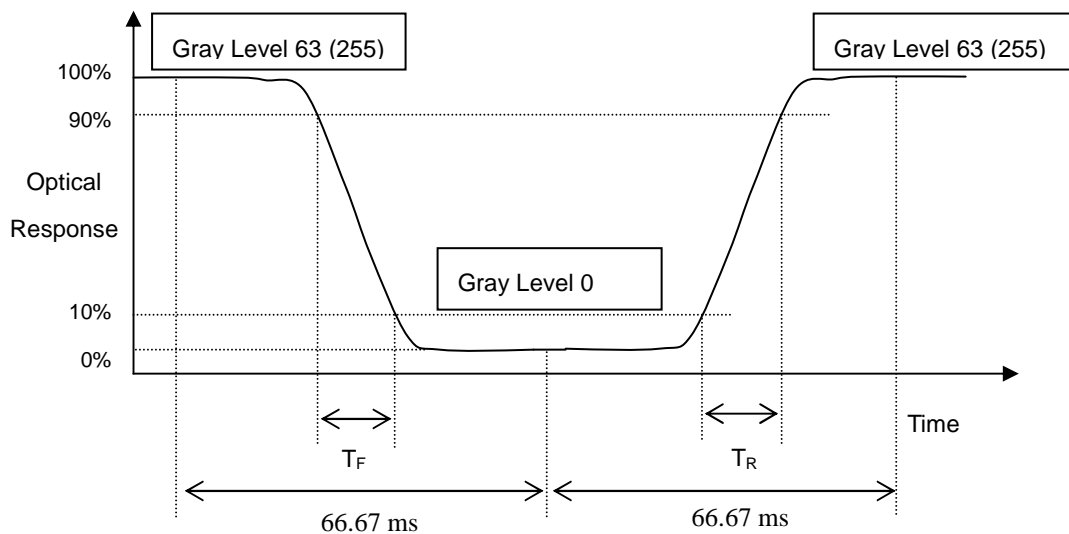

Note (4) Definition of Luminance of White,  $L_C$ :

Measure the luminance of gray level 63 (255) at center point

$$L_C = L(5)$$

$L(x)$  is corresponding to the luminance of the point X at Figure in Note (6).

Note (5) Measurement Setup:

The LCD module should be stabilized at given temperature for 20 minutes to avoid abrupt temperature change during measuring. In order to stabilize the luminance, the measurement should be executed after lighting Backlight for 20 minutes in a windless room.

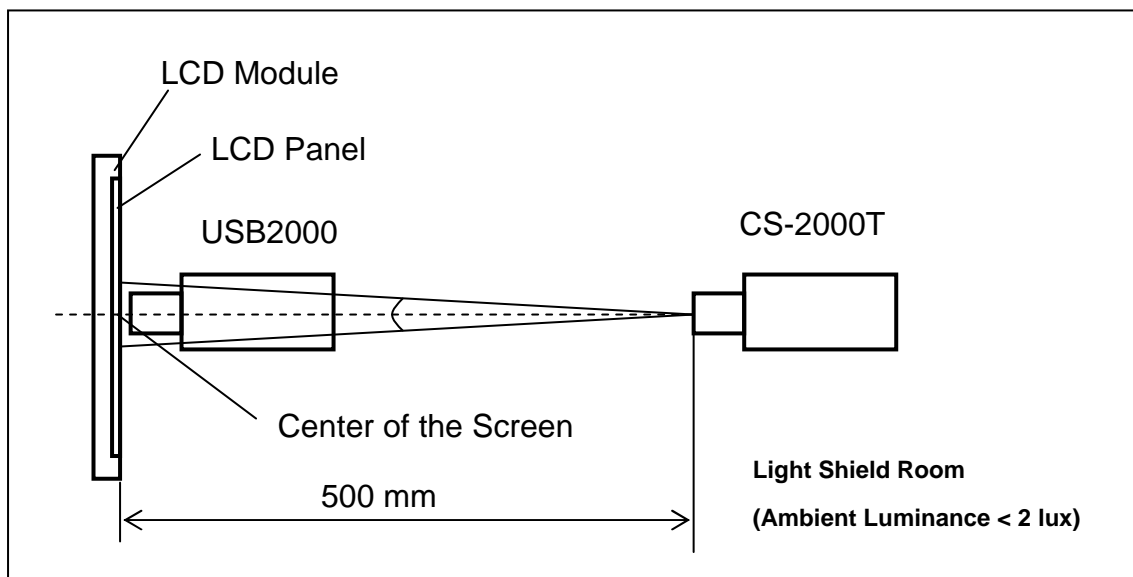

Note (6) Definition of White Variation ( $\delta W$ ):

Measure the luminance of gray level 63 (255) at 9 points

$$\delta W = \frac{\text{Maximum [L (1), L (2), L (3), L (4), L (5) , L (6), L (7), L (8), L (9)]}}{\text{Minimum [L (1), L (2), L (3), L (4), L (5) , L (6), L (7), L (8), L (9)]}}$$

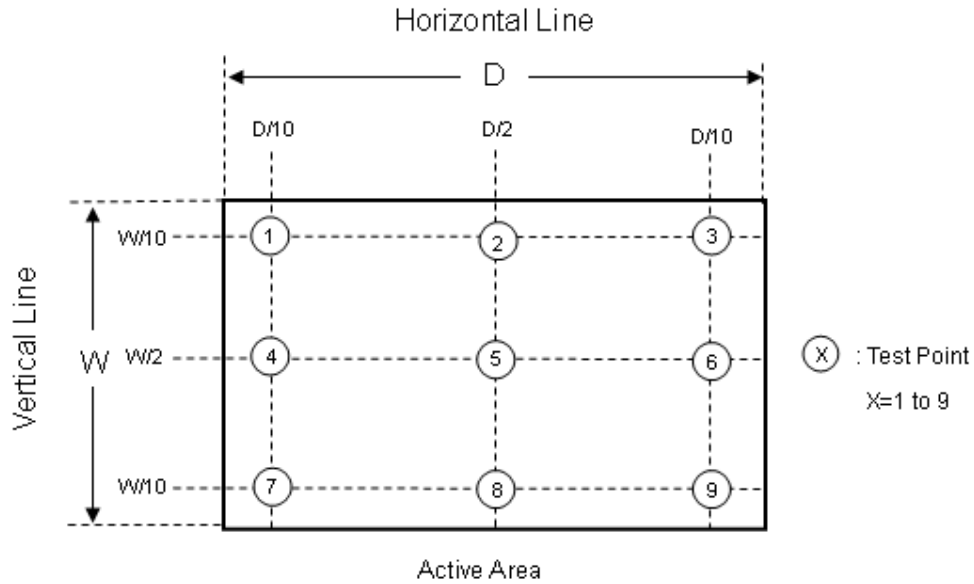

8. RELIABILITY TEST CRITERIA

Test Item	Test Condition	Note
High Temperature Storage Test	(85°C, 240 hours)	(1)(2)
Low Temperature Storage Test	(-30°C, 240 hours)	
Thermal Shock Storage Test	(-30°C, 0.5hour $\longleftrightarrow$ 85°C, 0.5hour; 1hour/cycle,100cycles)	
High Temperature Operation Test	(80°C, 240 hours)	
Low Temperature Operation Test	(-30°C, 240 hours)	
High Temperature & High Humidity Operation Test	(60°C, 90%RH, 240hours)	
Shock (Non-Operating)	(200G, 2ms, half sine wave, 1 time for $\pm X$ , $\pm Y$ , $\pm Z$ .)	(3)
Vibration (Non-Operating)	(1.5G, 10 ~ 300 Hz, 10min/cycle, 3 cycles each X, Y, Z)	(3)

Note (1) There should be no condensation on the surface of panel during test.

Note (2) Temperature of panel display surface area should be 85 °C Max.

Note (3) At testing Vibration and Shock, the fixture in holding the module has to be hard and rigid enough so that the module would not be twisted or bent by the fixture.

Note (4) In the standard conditions, there is no function failure issue occurred. All the cosmetic specification is judged before reliability test.

9. PACKAGING

9.1 PACKING SPECIFICATIONS

- (1) 16pcs LCD modules / 1 Box
- (2) Box dimensions: 465 (L) X 362 (W) X 314 (H) mm
- (3) Weight: approximately 15Kg (16 modules per box)

9.2 PACKING METHOD

(1) Carton Packing should have no failure in the following reliability test items.

Test Item	Test Conditions	Note
Vibration	ISTA STANDARD Random, Frequency Range: 2 – 200 Hz Top & Bottom: 30 minutes (+Z), 10 min (-Z), Right & Left: 10 minutes (X) Back & Forth 10 minutes (Y)	Non Operation
Dropping Test	1 Angle, 3 Edge, 6 Face, 61 cm	Non Operation

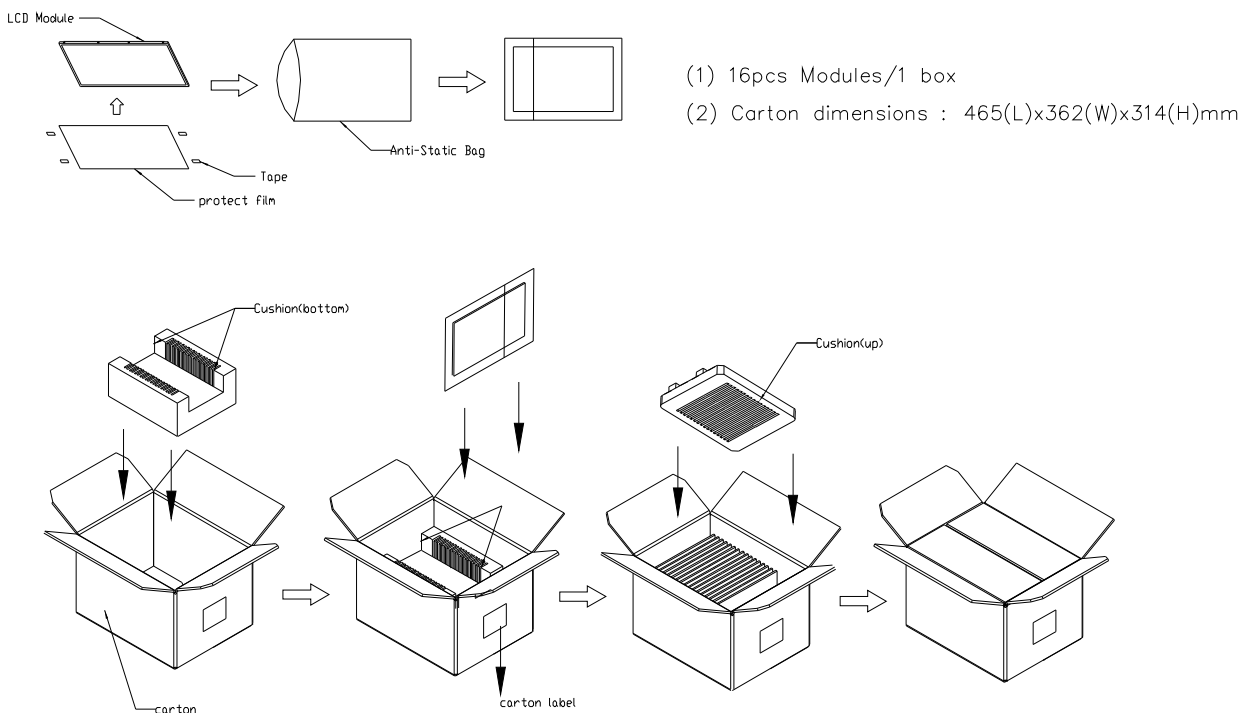

**Figure. 9-1 Packing method**



Sea / Land Transportation (40ft Container)

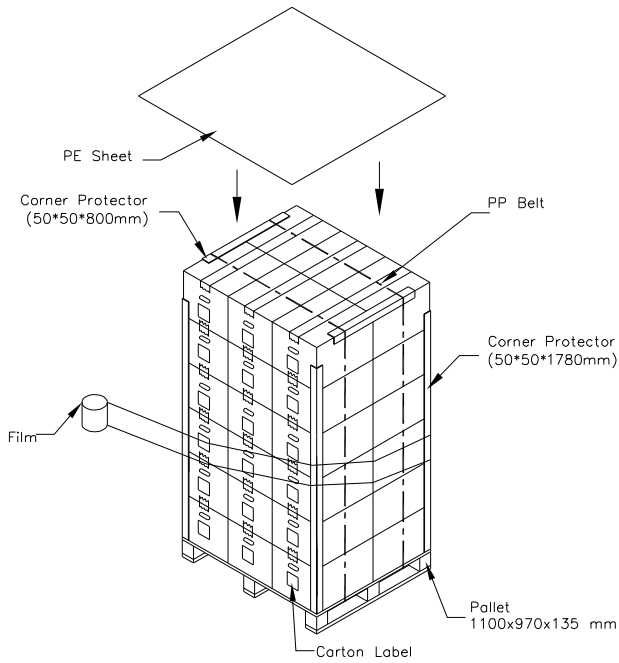

Air Transportation

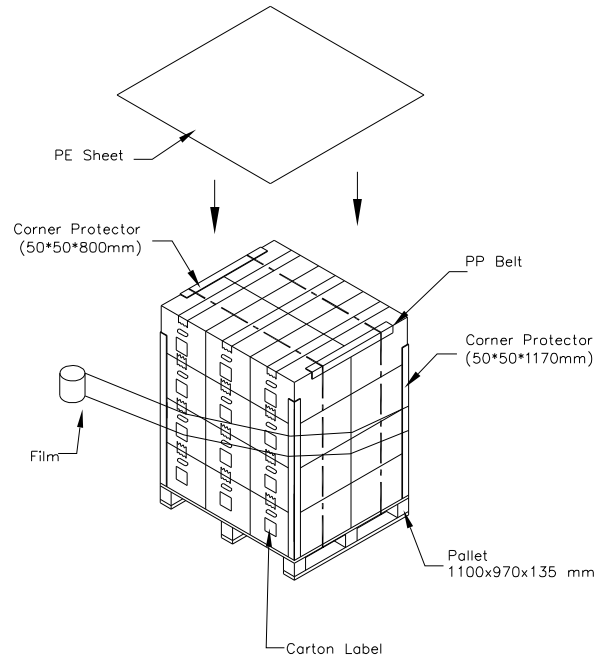
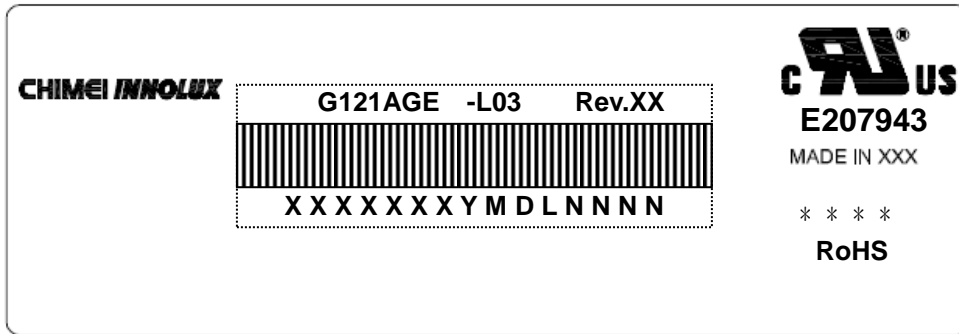

Figure. 9-2 Packing method

10. DEFINITION OF LABELS

10.1 CMO MODULE LABEL

The barcode nameplate is pasted on each module as illustration, and its definitions are as following explanation.



- (a) Model Name: G121AGE -L03
- (b) Revision: Rev. XX, for example: A1, B1,C1, C2 ...etc.
- (c) Serial ID: XXXXXXXXYMDLNNN

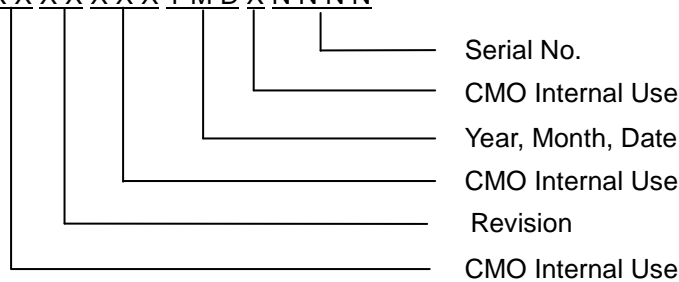

Serial ID includes the information as below:

- (a) Manufactured Date: Year: 1~9, for 2001~2009  
 Month: 1~9, A~C, for Jan. ~ Dec.  
 Day: 1~9, A~Y, for 1<sup>st</sup> to 31<sup>st</sup>, exclude I , O and U
- (b) Revision Code: cover all the change
- (c) Serial No.: Manufacturing sequence of product

## 11. PRECAUTIONS

### 11.1 ASSEMBLY AND HANDLING PRECAUTIONS

- (1) Do not apply rough force such as bending or twisting to the module during assembly.
- (2) To assemble or install module into user's system can be only in clean working areas. The dust and oil may cause electrical short or worsen the polarizer.
- (3) It's not permitted to have pressure or impulse on the module because the LCD panel and Backlight will be damaged.
- (4) Always follow the correct power sequence when LCD module is connecting and operating. This can prevent damage to the CMOS LSI chips during latch-up.
- (5) Do not pull the I/F connector in or out while the module is operating.
- (6) Do not disassemble the module.
- (7) Use a soft dry cloth without chemicals for cleaning, because the surface of polarizer is very soft and easily scratched.
- (8) It is dangerous that moisture come into or contacted the LCD module, because moisture may damage LCD module when it is operating.
- (9) High temperature or humidity may reduce the performance of module. Please store LCD module within the specified storage conditions.
- (10) When ambient temperature is lower than 10°C may reduce the display quality, the response time will become slowly.
- (11) Do not keep same pattern in a long period of time. It may cause image sticking on LCD.

### 11.2 SAFETY PRECAUTIONS

- (1) Do not disassemble the module or insert anything into the Backlight unit.
- (2) If the liquid crystal material leaks from the panel, it should be kept away from the eyes or mouth. In case of contact with hands, skin or clothes, it has to be washed away thoroughly with soap.
- (3) After the module's end of life, it is not harmful in case of normal operation and storage.

12. MECHANICAL CHARACTERISTICS

